



# **Air Jacketed CO<sub>2</sub> Incubator FM-CIA-A100**

## Index

<b>Sr.no</b>	<b>Title</b>	<b>Page no</b>
1.	Safety Measures	2
2.	Introduction	5
3.	Features	5
4.	Specifications	6
5.	Applications	6
6.	Instrument Introduction	7
7.	Installation	8
8.	Operations	13
9.	Maintenance	20
10.	Troubleshooting	23
11.	Circuit Diagram	25

## 1. Safety Measures

1. When using this product for the first time, kindly read this manual carefully.
2. The CO2 incubator can only be operated by trained and authorized personnel.
3. The CO2 incubator must be inspected and maintained at specified time intervals.
4. The CO2 incubator heats up through the back to achieve the purpose of constant temperature of the box. To ensure the normal operation of the machine and ventilation and heat dissipation, the back left and right sides of the incubator are at least 30cm away from the wall, and the air inlet and outlet must not be blocked by obstacles.
5. The temperature in the CO2 incubator will fluctuate in case of machine failure or power failure. If it cannot be repaired in a short time, kindly take out the medium and transfer it to another place that meets the temperature requirements of the medium for storage to avoid damage to the medium.
6. Where the equipment is marked with a symbol , you need to consult this manual when using it, to find out the potential nature of the danger and the countermeasures that must be taken.
7. Kindly use the equipment according to the method specified in this manual. If the equipment is not used according to the method specified by the manufacturer, the protection provided by the equipment may be damaged.

**This manual includes important safety regulations, kindly be sure to follow the instructions.**

### **Warning (May Cause Serious Property Damage or Casualties)**

- This product must be reliably grounded and away from sources of electromagnetic interference (A zero line cannot be used as a grounding line).
- Use a power source that matches the electrical parameters indicated on the nameplate of this device.
- Do not insert metal objects such as nails or iron wires into any openings or gaps in the device or any vents used for internal air circulation, otherwise electric shock or injury may occur due to accidental contact of the above objects and moving parts.
- Do not allow the product to be unplugged or plugged in without turning off the power switch during operation.
- Do not damage the power plug or power cord. If the user wants to remove the plug from the power socket, he should hold the power plug rather than pull the power cord lead. If the plug connection is loose, do not use the power plug again, do not allow to lengthen or shorten the power cord, otherwise, it may cause fire or electric shock.
- Users must not disassemble, repair, or modify the equipment by themselves. If any of the above operations is performed by an unauthorized person, fire or personal injury may result from improper operation.
- The user-provided carbon dioxide cylinders are pressure vessels and must comply with the National Pressure Vessel Management Code.

## Air Jacketed CO2 Incubator FM-CIA-A100

- Do not store volatile or flammable items in this device, otherwise, an explosion or fire may be caused.
- There must be no obstruction of the air circulation hole in the use process, and the circulation air duct must be smooth.

### **Warning (Be Likely to Cause Serious Property Damage or Casualties)**

- Operations can be done after fully reading and understanding the product instructions.
- 304 stainless steel liners cannot resist acid, kindly pay attention to anti-corrosion measures, and do not use acidic media in the cabinet.
- The product power cord must be unplugged when performing the following operations:
  1. Replace the fuse
  2. The product has failed and needs to be repaired
  3. The product has not been used for a long time
  4. The product is moved to other places.
- Kindly use a grounded power socket to prevent electric shock. If the power socket is not grounded, it must be installed by a qualified technician.
- Avoid direct glaring at the UV light, because UV light may cause temporary or permanent damage to eyes.
- When the product is placed on a workbench, the feet should be fixed to prevent the product from falling and causing personal injury.

### **Warning (Be Likely to Cause the Product not to Work Normally or Affect the Service Life)**

- When handling the product, care should be taken to avoid damage to the vulnerable components such as the meter on the panel.
- This equipment should be installed on solid ground to keep it level. If the ground is not solid enough or the installation site is not suitable, personnel may be injured due to the overturning of the equipment.
- After each test, the product should be wiped off the water inside the liner to avoid corrosion of the liner and affect its service life.
- Do not open or close the cabinet door by gravity, otherwise it may cause the door to fall off and the product to be damaged.
- Do not apply extra pressure to the glass door or scratch the glass surface with sharp objects, otherwise the door may be broken or have scratches.
- Do not place water-containing containers or heavy objects on the product, to avoid water splashing on the product thus, causing a short circuit or electric shock hazard, or heavy objects falling.
- This product must not be placed outdoors.

### Installation Site

For proper operation and optimal performance, the equipment should be installed in a location that meets the following conditions:

- A location that will not be directly affected by direct sunlight or airflow from the air conditioner.
- A place with clean air and adequate ventilation (do not install in a tightly closed room).

**Note:** The ambient temperature must be at least 5°C lower than the set temperature.



### Warning

If the device is used in a small, closed room, the concentration of CO<sub>2</sub> in the air may increase and it may have harmful effects on the human body.

**When the device uses CO<sub>2</sub> control, it is necessary to ventilate the room frequently.** Concentrations of gases in closed rooms will gradually increase and high concentrations of CO<sub>2</sub> gas will be dangerous to humans. In addition, when CO<sub>2</sub> is used, direct intake of air from the cabinet should be avoided when opening the door.

- A place away from heat source.
- A place with a solid, level surface.



### Warning

Kindly choose a flat and solid floor for installation, which will prevent the device from tipping over. Improper installation may result in water spillage or personal injury due to overturning of the equipment.

- A place where there is no flammable or corrosive gas.



### Warning

Do not use this device outdoors. If the device is exposed to rain, it may cause leakage or electric shock.

Do not place the device in a wet location or in a location that may be splashed by water. Otherwise, it may cause leakage or electric shock due to low insulation degree.

- A place where high humidity does not easily occur.



### Warning

Do not install the device in a location where flammable or volatile gases are present, as this may cause an explosion or fire.

Do not install the device in a place where there is an acidic or corrosive gas, otherwise, it may cause leakage or electric shock due to corrosion.

## 2. Introduction

**Air Jacketed CO<sub>2</sub> Incubator FM-CIA-A100** employs air-jacketed temperature control technology to ensure an optimal and stable growing environment for cell and tissue cultures. Built-in microprocessor controller technology with LED display and 50 L working chamber capacity. Enhanced safety features include infrared sensor for CO<sub>2</sub> concentration and UV lamp for sterilization, promotes cell growth through precise control of humidity, temperature, and CO<sub>2</sub> gas while minimizing the potential for contamination.

## 3. Features

- ✓ Microcomputer controlled system
- ✓ PID controller to control several parameters
- ✓ UV Lamp as a sterilizing agent
- ✓ LCD touch screen displays: Temperature, CO<sub>2</sub> concentration, and run-time
- ✓ 2 perforated stainless-steel shelves and 50 L inner chamber capacity
- ✓ Infrared (IR) sensor uses split-beam technology for CO<sub>2</sub> control in fluctuating temperature and humidity conditions
- ✓ Rapid humidity recovery using a large directly heated water reservoir
- ✓ CO<sub>2</sub> incubator pressure regulator
- ✓ Water level and over temperature alarm with audible and visual alert
- ✓ Tightly sealed inner door made of tempered safety glass
- ✓ Excellent quality gas circuit valve for stable CO<sub>2</sub> concentration and less CO<sub>2</sub> consumption
- ✓ Working chamber adopts round angle structure, easy to clean

## 4. Specifications

Model No.	FM-CIA-A100
Capacity	50 L
Heating	Air jacket
Temperature range	RT +5 to 60°C
Control type	PID control
Temperature fluctuation	≤ ±0.2°C (at 37°C)
Temperature uniformity	≤ ±0.3°C (at 37°C)
Time setting	999 h or continuous
Alarm system	Over-temperature alarm; CO <sub>2</sub> Concentration alarm; Temperature sensor error alarm; Water-shortage alarm.
Interior material	Stainless steel
Exterior material	Cold-rolled steel with painting
Door type	Double door
Insulation Material	Polystyrene film
CO <sub>2</sub> control sensor	Infrared sensor
CO <sub>2</sub> measuring range	0 to 20 %
CO <sub>2</sub> concentration control accuracy	CO <sub>2</sub> concentration control error 5% ± 0.1 %
Humidification type	Water tank for natural evaporation
Sterilization type	UV lamp
Shelves	2 pcs/adjustable
Caster type	Foot master caster
Interface	USB port
Power supply	220 V±10%, 50/60 Hz
Maximum power consumption	350 W
Internal dimension (W×D×H)	368×387×408 mm
External dimension (W×D×H)	500×527×821 mm
Packaging dimension (W×D×H)	655×680×970 mm
Gross Weight	69 kg

## 5. Applications

CO<sub>2</sub> incubators are designed to maintain adequate interior moisture to prevent the drying out of cultures. These air jacketed CO<sub>2</sub> incubators are widely used for a broad range of applications that includes: Tissue engineering, In vitro fertilization, Neuroscience, Cancer research, Stem cell research, Regenerative medicine, Mammalian cell research.

### 6. Instrument Introduction

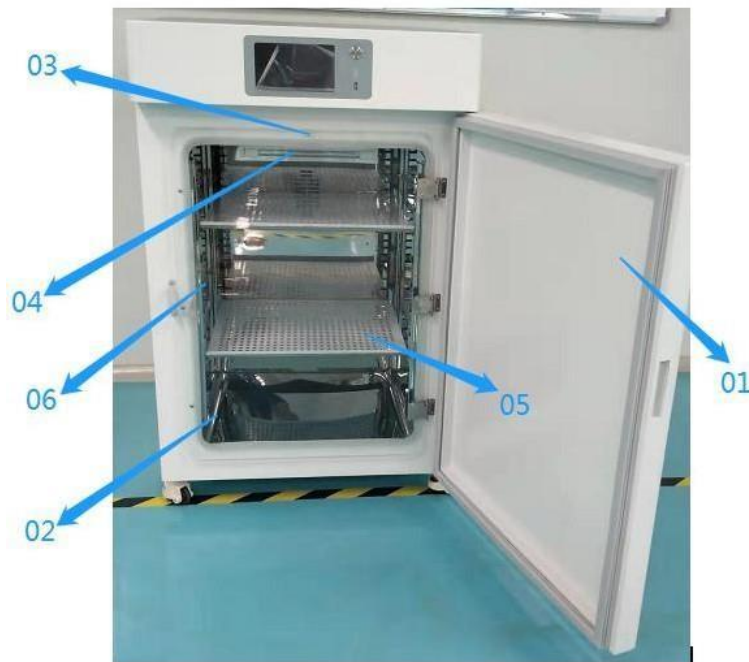

The CO<sub>2</sub> incubator is composed of the cabinet body, the liner, the temperature control unit, CO<sub>2</sub> concentration control system.

- 1. Outer door:** The outer door is attached to the body frame by a magnetic seal strip.
- 2. Inner door:** The inner door is made of tempered glass. Avoid striking and scratching the glass during usage.
- 3. Door switch:** It is used to detect whether the door is closed or not, once the outer door is open, the CO<sub>2</sub> electromagnetic valve and circulating fan will stop working.
- 4. UV lamp:** It is used to sterilize the work chamber.
- 5. Partition:** It is used to place incubation utensils.
- 6. Ladder:** It is used to place shelves and adjust the height of shelves.



## 7. Installation

### 7.1 Use Environment

To prevent the incubator from being contaminated, select a suitable installation site and completely sterilize the components in the cabinet.

- To prevent bacteria from entering the incubator, kindly avoid placing the equipment in the following places: places with excessive ventilation, large flow of people, places near doors, air conditioners, fans, etc.
- To obtain a better cultivation effect, kindly place the equipment in a sterile room.
- Use clean containers: The pollution is mainly caused by the containers stored in the box, such as culture dishes, culture bottles, etc., so kindly make sure to use clean and sterile containers.
- Ensure the air circulation around the product: at least 30cm of space should be left at the rear and sides.

### 7.2 Installation

#### Remove all the package materials

Inspect the surface of the main body to make sure whether there is scratch, deformation, or uncorrelated things; open the door of the CO2 incubator to ensure the air circulation of the equipment. If the shell panel is dirty, kindly wipe the dirt using neutral detergent, and clean the residual neutral detergent with clean water (Undiluted detergent will damage the plastic components, kindly dilute the detergent with reference to the description of the detergent.) Using the wet cloth wipe the shell after cleaning, and then using a dry cloth wipe the shell panel.

#### Adjustment of Foot master Caster

Clockwise rotate the caster' red part to lower the base feet and the height of the cabinet. Low down all four casters can move the cabinet position. Counterclockwise rotation casters' red part can raise the base leg and height of the cabinet. Raise all four casters can at the same time fix the cabinet. Adjust the four-foot -masters to make the cabinet stable.

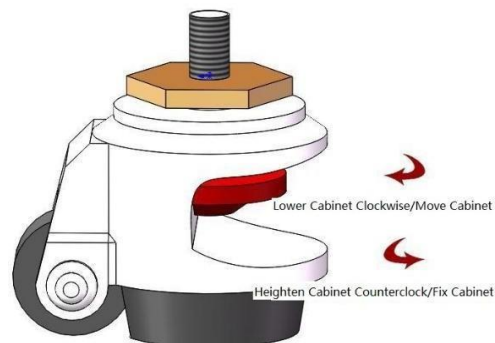

## Grounding



### Warning

Kindly use a power socket with ground wire to prevent electric shock. If the socket is not grounded, there must be qualified engineering and technical personnel to do it.

Don't pass through the gas pipe, power supply pipe, telephone line, or lightning rod to equipment grounding. This kind of grounding may cause electric shock because of the loop is incomplete.

## 7.3 Connection of CO2 tank



### Warning

Use a liquefied CO2 tank. Don't use the siphon-type tank.

CO2 use must be for medical CO2, purity should not be less than 99.9%.

### 1. The regulating of the CO2 tank

- It must be equipped with a carbon dioxide cylinder and a carbon dioxide pressure-reducing valve. (The carbon dioxide cylinder is a pressure vessel, which is prepared by the customer).
- Install a pressure relief valve on the cylinder. The high-pressure gauge (0-25Mpa on the right) is the pressure inside the cylinder, which shows the gas volume in the cylinder, and the low- pressure gauge (0-0.25Mpa on the left) is the output pressure.

### Attention for using gauges:

- The operating principle of the gauges is that the spring of the screw will withstand the diaphragm and will make the diaphragm open or close. Loosening the rotary knob, the diaphragm will be closed, and the gas circuit will be closed accordingly. Fastening the rotary knob, the diaphragm will be open, and the gas circuit will be open accordingly. Whenever the CO2 tank valve is closed, such as changing of CO2 tank or for other reasons, kindly anticlockwise loosen the rotary knob to the end before fastening the rotary knob to make the gas circuit close. Otherwise, the low-pressure gauge may be damaged as the reason of the instantaneous pressure is too high when opening the CO2 tank valve.
- Kindly open the pressure gauge slowly, and if loosening the rotary knob, kindly loosen it to the end, and if fastening the rotary knob, kindly fasten it to the end, as half on or half off will lead to leakage, and if this situation last long, it will result in the instability of the pressure gauge or the breaking of it.
- Normally, the high-pressure gauge will show between 5-7Mpa; however, if the ambient temperature is less than 15°C, it will show 4-5Mpa. We suggest that the pressure is not higher than 8Mpa.
- When the high-pressure gauge shows between 2-3Mpa, it means that there is no liquid CO2, and at the same time, the pressure and the gas output are unstable, kindly

## Air Jacketed CO<sub>2</sub> Incubator FM-CIA-A100

- observe it timely, to make sure that changing a new CO<sub>2</sub> tank at the right time.
- It would be better to adjust the low-pressure gauge to make it show 0.04Mpa-0.08Mpa; it needs to be adjusted many times to obtain a stable pressure of the low-pressure gauge at the first time of use. Kindly make sure to do this way whenever change the CO<sub>2</sub> tank.
  - The CO<sub>2</sub> pressure regulator needs to be calibrated regularly, and the gauges need to be tested regularly, to ensure accuracy and reliability when adjusting the pressure. Kindly repair it timely when there is a leakage of the CO<sub>2</sub> pressure regulator and the pointer of the gauges cannot work well.
  - If the CO<sub>2</sub> pressure regulator is frozen, kindly thaw it with hot water or steam, and cannot be thawed with flame. Kindly wipe the water on the CO<sub>2</sub> pressure regulator after thawing.

### 2. Connecting the Air Intake Tube

#### 1. Installation components

##### Check installation components and tools

- (1) Check accessories for pressure-reducing valve.
- (2) Check installation tools.
- (3) Check the remaining gas in cylinders.

The specific parts and tools required are as follows:



(1) Pressure-reducing valve



(2) Live wrench (maximum opening 43mm)

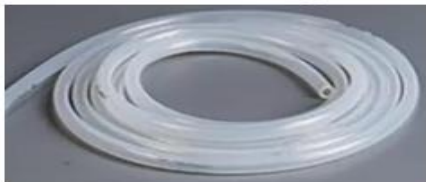

(3) Silicone hose



(4) Spring clip



(6) Cylinder connection port

### 2. Installation steps

First, check that the gauge of the pressure-reducing valve is “0” and close the cylinder.

1. As shown in the picture, turn the pressure-reducing valve gas switch knob clockwise and tighten it to the closed state.



2. Install the pipe connection plug and adjust the live wrench to tighten the plug to prevent gas leakage. Connect the silicone tube to the socket. The other end is connected to the tank inlet.



3. Use the live wrench to tighten the pressure-reducing valve at the cylinder connection.
4. Open the gas cylinder and read the gas pressure indication of the cylinder (as shown in the right meter) to check the gas inventory of the cylinder.

After checking that the gas is not leaking, install the black pressure regulating knob and turn the clockwise to adjust the pressure to 0.1 MPa, as shown in the left meter.



Turn the pressure-reducing valve gas switch knob counterclockwise to open the switch to the maximum state.

**Note:** When installing with a live wrench, kindly tighten to the tightest condition. Make sure the black pressure knob is in the loosest state before opening the cylinder!

### 7.4 Requirements for Working Air Pressure

- During use, the high-pressure gauge should not be less than 2Mpa and the output pressure of the low-pressure gauge should not be more than 0.08Mpa
- Once inlet pressure exceeds 0.08 Mpa, it will destroy the CO2 sensor and HEPA filter. At first, the damage may be too slight to perceive, but if this malfunction happens many times, it will accumulate damage to the CO2 sensor and will damage the whole CO2 sensor, making it out of function. In addition, the HEPA filter is easily damaged due to pressure overload, resulting in CO2 gas leakage. Therefore, the life of the carbon dioxide sensor and HEPA filter is related to the intake pressure of carbon dioxide. If the intake pressure is well adjusted, the carbon dioxide sensor and HEPA filter can be effectively protected. CO2 sensor/HEPA high-efficiency filter are all consumables, expensive and difficult to replace, so it is necessary to adjust the intake pressure (0.04~0.08Mpa, the best price adjustment pressure is 0.05Mpa) to prolong the service life of carbon dioxide sensor/HEPA high-efficiency filter.
- When the machine is used for the first time, kindly set the secondary pressure of CO2 to 0.05MPa, for the secondary pressure to be too high to lead to the fall of the tube connected to the CO2 inlet of the machine, in this condition it will cause the leakage of the CO2 and the damage of the Used for the first time When using Excessive high secondary pressure may cause tube separate from incubator air inlet port and CO2 leakage. When air flowed into the incubator for the first time, CO2 secondary pressure should be set as 0.05MPa, which can avoid damage to the gas path.
- Increasing concentrations of CO2 gas is harmful to health and could even result in serious consequences like asphyxia and death. Once gas leakage is detected, timely maintenance is necessary.

## 8. Operations

### Preparation

Plug in the power supply, and the power indicator light will flash, which indicates the power is connected and it's at the standby status.

Confirming whether voltage stabilizer is needed according to installation environment, to ensure power voltage fluctuation not exceeding 220V + 5%.

### Main Interface Description



**1. Power on button:** When the button is pressed, the icon turns orange, indicating that it is turned on: if the icon is white, it indicates that it is turned off.



**2. Device status display:** In the case of a shutdown, "Not running" is displayed.

in the case of power-on, "Running" is displayed and a running icon is displayed. The trumpet button in this position is a mute button, which can control the opening and closing of the alarm sound, but it cannot eliminate the alarm.



**3. UV light button:** Use only when the machine is on standby (the ON key of the display screen is white). The UV key opens for the orange display.



**4. Solenoid valve button:** The solenoid valve cannot be operated when the door is open. When the door is closed: if the solenoid valve is turned on, the icon turns orange; if the solenoid valve is closed, the icon turns white. If the solenoid valve is turned on for the first time, there will be a delay of several seconds, and the solenoid valve will automatically act according to the gas concentration in the cabinet.



**5. USB button:** Press the button after inserting the U flash drive, and the icon turns orange, when the lower middle position shows "storing data", indicating that the U flash drive works normally; kindly press the button again before unplugging the U flash drive, when the display shows "U flash drive has been successfully removed", then the user can unplug the U flash drive.



**6. Real-time monitoring:** Temperature: Display the temperature in the incubator. CO2 concentration: Display the CO2 concentration in the incubator.

**TIME:** The incubation time countdown value. When the incubation conditions are satisfied, the countdown shall be started in hours; when the value is reduced to 0, the alarm shall be sounded and the "Incubation Complete" sign is displayed in the lower right position. The alarm can be eliminated by opening or closing the door.



**7. Data display:** Press this button to enter the temperature curve display interface.

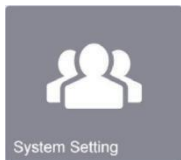

**8. System setting:** Used for customer self-programming programming parameters settings.



**9. Advanced setting:** Users cannot access without authorization, or it may affect the normal operation of the device.

## Filter Time:

**10. Filter time:** When the filter time (calculated according to the ventilation time) is greater than 3000 hours, an alarm will be generated and the prompt “kindly replace the filter” will occur to prompt the user to replace the filter.

## System Setting Interface Description:

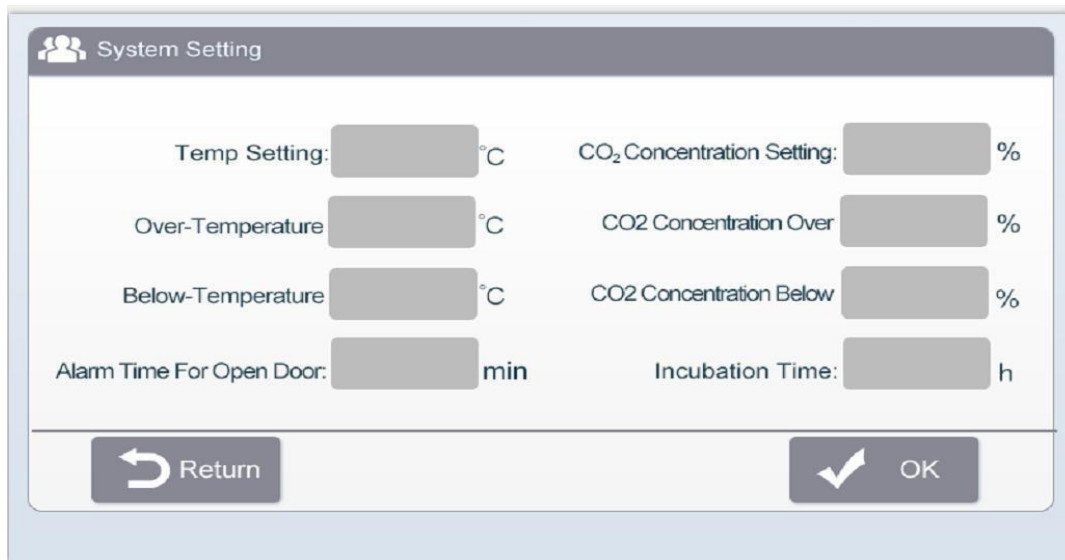

Temp Setting: [ ] °C

**1. Temperature setting:** Set the temperature inside the incubator. The maximum temperature setting is 60°C.

CO<sub>2</sub> Concentration Setting: [ ] %

**2. CO<sub>2</sub> concentration setting:** Set the CO<sub>2</sub> concentration in the incubator, the maximum is 20%.



## Air Jacketed CO2 Incubator FM-CIA-A100

Alarm Time For Open Door:  min

**3. Door open alarm time:** Set the door open alarm time,

and the unit will be in minutes. When the door opening time exceeds the set time, the alarm sounds, and when the door is closed, the alarm can be eliminated. There is no alarm in the factory setting.

Incubation Time:  h

**4. Incubation time:** set the incubation time, and the unit will be in hours. After setting the time, the corresponding value will be displayed on the main interface's TIME place. When the incubation condition is reached, the countdown will be started; up to 999 hours can be set and the factory setting is 0.

Over-Temperature  °C

**5.(Over temperature °C alarm) Over temperature alarm:** set the value, when the temperature exceeds the set value, it will generate an alarm and display the "high temperature" sign in the lower right. Only when the temperature is restored to this range, the "high temperature" sign will disappear; the maximum setting is 10°C and the factory setting is 1°C.

CO2 Concentration Over  %

**6. (CO2 concentration exceeds % alarm) Over concentration alarm:** set the value, when the concentration exceeds the set value, an alarm will be generated and the "high gas concentration" sign will be displayed at the lower right. Only when the concentration is restored to this range, the "high gas concentration" sign will disappear; the maximum setting is 10% and the factory setting is 1%.

Below-Temperature  °C

**7. Low-temperature alarm:** Set the value, when the temperature is lower than the set value, it will produce an alarm and show the "low temperature" sign at the lower right. Only when the temperature returns to this range, the sign of "too low temperature" disappear; the maximum temperature can be set to 10 and the factory can be set to 1.

CO2 Concentration Below  %

**8. (Over-temperature temperature alarm) Over-temperature alarm:** Set the value, when the temperature exceeds the set value, the alarm will be generated, and the "over-temperature" sign is displayed at the lower right. Only when the temperature restores to this range, the mark of "super high temperature" disappear; the maximum temperature can be set to 10 degrees C, and the

factory can set it to 1 degree C.



**9. OK button:** Press this button, and all the set values will be saved, otherwise the original value will still be displayed.



**10. Return button:** Press this button, the set values for incubation time, high-temperature alarm, and CO2 concentration alarm will not be saved. However, the set values for temperature setting, CO2 concentration setting, and door open alarm time will be saved.

### U flash drive instructions:

1. Insert the U flash drive when the power is turned on. Press the U flash drive button, and that the U flash drive is connected successfully or U flash drive is not connected will be displayed. If the connection is successful, the system enters the next step.
2. After the U flash drive is connected successfully, it will display the data being stored. Once every minute, the data will be stored (every time the data is stored, a buzzer will be sounded once). During the data storage process, an EXCEL table of WD01 will be created. A table can store 120 temperature values and the corresponding time values. When these 120 data are stored a WD02 EXCEL table will be automatically created, and so on.
3. After the data is stored, the user can unplug the U flash drive when the display shows that it is successfully removed, and then insert the U flash drive into the computer to read the data (it is recommended to use WPS2003 to open it, since other software may cause data to be garbled).

### Precautions for U flash drive:

1. Kindly do not press the U flash drive button and pull out the U flash drive frequently.
2. If a USB flash drive is inserted, if the connection fails to display, kindly reinsert the USB flash drive, and press the USB flash drive button again. If the connection still fails, check if the U flash drive interface is loose, the user can also try to reboot the device or format the USB flash drive.
3. It is recommended to cut each read data into the computer to save and clear the USB flash drive to avoid the next time you insert the USB flash drive, data cannot be stored, or data can be disturbed.
4. Kindly avoid cutting off the power during use, the previous data cannot be lost after the device is powered off or the device is restarted, and the U flash drive needs to be re-operated after the power is on.

### Alarm Description:

The mute button only clears the alarm sound but does not eliminate the alarm message unless the device returns to normal operation status.

### Attention for Use

- **Special attention:** When carrying out the culture test on the medium, wait for the incubator to reach the corresponding temperature environment before putting the medium into the medium for cultivation operation, and never put the medium in when the box is just powered on!
- Remove all packaging components (including the protective foam in the box and the base of the box) before use, check the accessories and materials according to the packing list, and use alcohol to clean the product once.
- **Power supply voltage:** This equipment uses a 220V/50Hz AC power supply. If the operating voltage is lower than 198V or higher than 242V, a suitable automatic voltage stabilizer must be installed to cooperate with it.
- To use this carbon dioxide incubator, the power supply is required to have a low-voltage air circuit breaker and leakage protection device.
- It is necessary to use a dedicated independent socket and conduct reliable grounding to ensure good grounding after the equipment is connected, and the length of the power cord must not be arbitrarily extended. If it really needs to be extended, be sure to use a copper core wire of 2.5mm<sup>2</sup> or more, and the cross-sectional area of the copper core wire in the wall connected to the power socket must also be guaranteed to be above 4mm<sup>2</sup>
- it is strictly forbidden to put flammable and explosive dangerous goods and highly corrosive acids and alkalis into the carbon dioxide incubator
- Do not connect the neutral wire (N terminal) and the ground wire (E terminal) on the socket, otherwise, the carbon dioxide incubator shell will be electrified and an electric shock accident will occur.
- The power cord cannot be used in bundles, cannot be pressed under heavy objects, and cannot be close to heat sources such as compressors
- Do not place the device in a position where it is difficult to access the disconnecting device
- The equipment should be placed in a dry, flat, non-toxic, harmful, strong electromagnetic field and indoor place without radiant energy, and should avoid direct sunlight. There should be a certain space around the equipment for easy maintenance.
- To ensure the accuracy of temperature control, it is recommended to use it in an environment of (18~30) °C.
- The use of this equipment must be equipped with a steel cylinder containing 99.9% high-purity carbon dioxide gas, and a carbon dioxide pressure-reducing valve must be installed. The steel cylinder should be placed near the incubator and connected with the "carbon dioxide inlet" at the rear of the incubator with a hose, and the joints are fixed with spring clamps after connection.
- When the incubator is in use, set the minimum temperature at least higher than the ambient temperature (5-7) °C. When the ambient temperature and the set temperature are less than (RT+5°C), use the air conditioner to reduce the ambient temperature. It is recommended to use it in an environment of 18°C-30°C to ensure the accuracy of the temperature control of the carbon dioxide incubator.
- If humidity is required, kindly inject a proper amount of distilled water into the bottom of the inner chamber and close the door.

## Air Jacketed CO<sub>2</sub> Incubator FM-CIA-A100

- When the pressure of the carbon dioxide cylinder is lower than 2MP, the gas cylinder should be replaced in time.
- Use alcohol to clean the working chamber of the carbon dioxide incubator.
- In units with unstable power supply, it is best to equip them with high-performance voltage stabilizers (UPS) to reduce failures caused by voltage instability.
- Do not open the box door to look directly at the ultraviolet lamp during ultraviolet disinfection to avoid damage to the eyes.
- In the case of abnormal shutdown or manual shutdown under normal use, the water vapor in the inner tank needs to be wiped clean before restarting, and the glass door should be opened to ventilate and dry.
- The product shall not operate the display screen during the cultivation process.
- Kindly use a non-metallic USB flash drive for data storage or export.
- When the equipment is in use, the displayed temperature and carbon dioxide concentrations should be calibrated regularly.
- To ensure the effectiveness of the cultivation when the equipment is in use, kindly put it into the culture dish after the equipment is running stably and close the door of the chamber immediately after putting it in the culture dish.
- The cultivation effect of the equipment should be verified before use.
- Check the service life of the filter before use, kindly use a HEPA high-efficiency filter.
- When the petri dish is placed inside the equipment, the ultraviolet light disinfection function shall not be used.

## 9. Maintenance

Frequency	Operations
Daily	Clean inside chamber and frame, door glass
Weekly	Clean the door sealing strip, wipe the UV lamp
Every 1-3 years	Change the door sealing strip
Every 1000 working hours	Change the UV light
Every 6 months	Change the air filter

1. Check the CO2 tank regularly to ensure it is not empty.
2. Check if there is any leakage in the CO2 intake pipe and connector.
3. Wipe the dust on the machine regularly, to prevent the dust from blocking the airway and electromagnetic valve
4. Be sure to add sufficient deionized or distilled water to the bottom of the humidification pan/inner chamber.
5. The incubator should be stored in a room where the relative humidity is not more than 80%, and there is no corrosive gas.
6. There should be shockproof, moisture proof, and other necessary protective measures during transportation. Do not transport upside down, handle with care.
7. Cleaning of the working chamber and sealing strip  
 Use a cotton cloth or towel soaked in distilled water to clean the entire interior (including ladder frames/partitions) and inner/outer door seals, Wipe the polluted inner cavity and the surface of the sealing strip with a cotton cloth soaked in alcohol (alcohol concentration is 75%), wipe off all foreign matter, and then wipe off the moisture on the inner cavity and sealing strip with a clean dry cotton cloth or towel, Let it stand for half an hour before it can be used normally.



Use protective gear (clothes, gloves, goggles, etc.) when cleaning with alcohol.

Kindly use designated reagents for cleaning, and do not use cleaning agents or disinfectants that may cause danger due to chemical reactions with equipment components or materials contained in the equipment. If in doubt about the compatibility of disinfectants or cleaning agents with equipment components or materials contained in equipment.

If hazardous substances leak on the surface of the device or enter the interior of the device, it should be thoroughly cleaned with alcohol, and then the residual moisture should be dried with a clean dry cotton cloth or towel before continuing to use.

8. Cleaning of exterior surfaces and glass doors, After cleaning contaminated surfaces with alcohol or thinner, wipe with a soft cotton cloth or towel.

9. Period of comprehensive maintenance  
The recommended cycle for comprehensive maintenance is one week or 100 working hours.

### **Maintenance method**

#### **a) Daily or weekly maintenance**

- Disinfection and cleaning of the operating area (refer to the instructions in Article 7)
- Clean the external surface and glass door around the operating area (refer to the instructions in Article 8)
- Check whether the various functions of the equipment are abnormal
- Record this maintenance

#### **b) Monthly maintenance**

- Cleaning of exterior surfaces and glass doors (refer to Section 7 for instructions)
- The surface of the inner cavity of the equipment box and the inner surface of the glass door must be wiped with 75% alcohol.
- After wiping, use a cotton cloth soaked in distilled water for a second cleaning. After cleaning, use a dry cotton cloth to absorb the residual moisture and ventilate to dry.
- Check whether the various functions of the equipment are abnormal
- Check the displayed temperature and displayed carbon dioxide concentration of the device and calibrate as required.
- Check the service life of the high-efficiency air filter and replace it in time. Document this maintenance.

#### **C) Annual maintenance**

- Check whether the hinge height of the tempered glass inner door is consistent
- Check the high-efficiency air filter for aging and air leakage, and replace it if necessary, usually every six months
- Check whether the sealing strip of the outer door is aging, shrinking, or not tightly sealed, and replace it if necessary, generally every 1-3 years
- Check that the non-self-resetting thermal cutout is working properly:
  1. Open the rear cover of the equipment, take out the insulation layer behind, and expose the thermostat to the air
  2. Disconnect the temperature sensor, simulate the failure of the temperature sensor, and place a temperature detection device inside the box to make it display the actual temperature of the equipment
  3. Adjust the setting temperature of the equipment to 60°C, so that the equipment is in a full-power heating state.
  4. When the measured temperature of the equipment rises to 75°C, start to observe the temperature change. After the measured temperature rises to a certain level, it will drop.
  5. Therefore, it is determined that the thermostat can work normally. If the

## Air Jacketed CO<sub>2</sub> Incubator FM-CIA-A100

displayed temperature has been rising above 90°C and continues to rise, it is determined that the thermostat is invalid.



After moving the box each time, it can be used normally after standing for 24 hours.



Every time you move the box, try to keep the box parallel to the ground, and the inclination angle should not be greater than 45°.

### 10. Troubleshooting

Kindly confirm whether the power is connected or not, whether the power cord is damaged, whether the fuse is good or not.

Failure phenomena	Checking site	Solution
UV light doesn't work	Holder	The light should connect well with its holder
	Light tube	Change it
	Ballast	Change it
	Circuit	Check the circuit
	Control panel	Change it
The button doesn't work	Control panel	Make sure the power connects well and the fuse is good.
		Check if the button is broken.
		Make sure the connecting wire is connected well.
		Change it
The blower doesn't work	Micro switch	Check whether the micro switch is damaged or works properly
	Blower	If the blower is broken. change it
	Circuit	Check the circuit
	Control panel	Change it
The display of CO2 concentration is not correct	Airway	Check if the airway falls off, bends, or is blocked
	Control panel	Change it
	Sensor	Connect with a CO2 concentration tester
	Solenoid valve	Check if the inlet and outlet of the solenoid valve have airflow
Temperature is abnormal	Sensor	Use the built-in temperature tester to test the temperature of the working chamber



## Air Jacketed CO2 Incubator FM-CIA-A100

	Ambient temperature	Make sure the Ambient temperature is higher at least 5°C than the setting temperature
Relative humidity	Too low	Increase the area of evaporation
	Too high	Decrease the area of evaporation
The Glassdoor cannot be closed tightly	Doorknob	Check whether the doorknob is loose
	Sealing strip	Check if the sealing strip is tilted or aging
No electricity in the equipment	Power Supply	The power supply is not connected well
	Power wire	Check if the power wire is damaged
	Fuse	Check if the fuse is good
	Transformer	Check whether the transformer works normally
	Control panel	Change it
The display doesn't work	Connection winding displacement	Check whether the connection winding displacement is in good contact.
	Display screen	Check whether the display is good
	Control panel	Change it
	Circuit	Check if the microswitch circuit is good
	Control panel	Change it



- (1) The above electrical parts must be operated by a qualified electrician in safety conditions (cutting off the power supply). The other parts are not allowed to be removed; otherwise, the user should take responsibility for them.
- (2) When failures do not occur, and the operator can't solve them, kindly notify our maintenance department immediately. For your safety, kindly do not maintain the equipment by yourself.
- (3) The maintenance of this equipment is undertaken by trained and recognized technicians.

## 11. Circuit Diagram

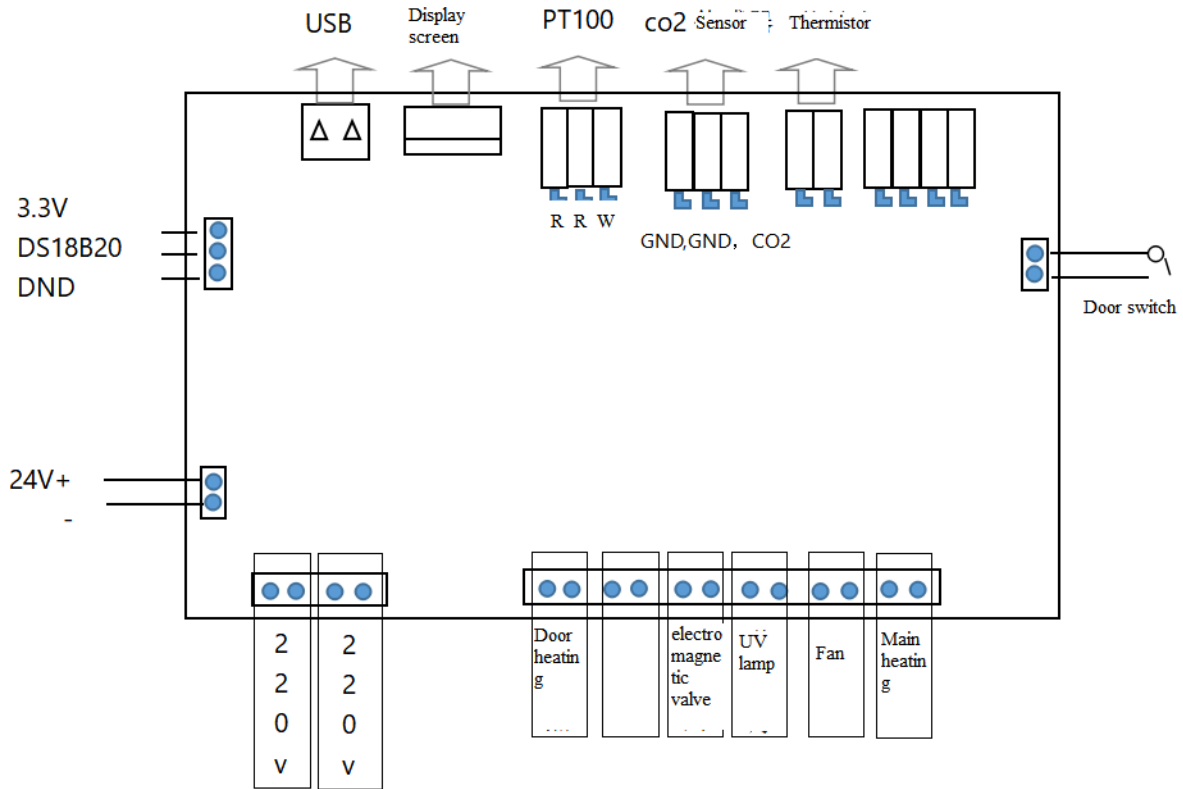

Fison Instruments Ltd 272 Bath Street Glasgow G2 4JR UK

**Email:** [info@fison.com](mailto:info@fison.com) | **Website:** [www.fison.com](http://www.fison.com)